



创新科技 追求卓越

广州西冠

机电设备有限公司

求生存 谋发展

创一流技术品牌

锐意进取 开拓创新



广州市西冠机电设备有限公司



广州西冠机电设备有限公司

V形带皮带轮图例

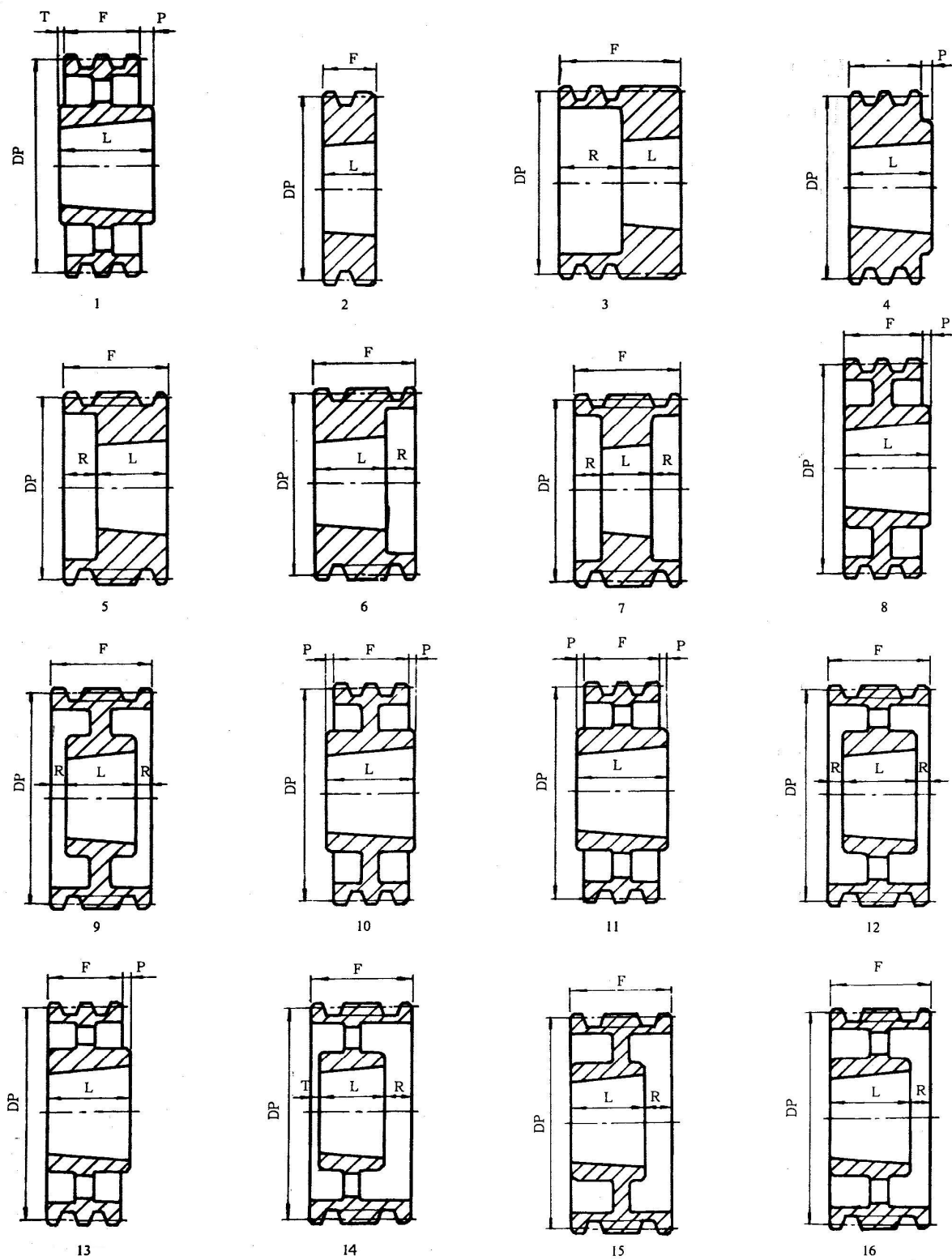



广州西冠机电设备有限公司

锥套嵌入式皮带轮

◆锥度锁紧设计原理简介

在锥度配合系统中，最著名的有“International”(国际)和“Morse”(摩斯)这两种系统。前者的锥度为每英尺长度上的直径变化是3.5英寸，锥角为 $15^{\circ}48'$ ，无自锁能力，在没有机械力的约束下，相配对的零件容易分离。典型的Morse锥度用于将钻头或铰孔锥固定到机床的轴心夹具上，其锥度为每英尺长度直径变化0.625英寸，锥角为 $2^{\circ}59'$ ，即使在有润滑条件下，这个锥度也仍然能保持自锁能力。

利用锥度原理将零件紧固于轴上，其实质是将轴向力转化为径向力。这种

结构应能产生最大的紧固力，同时又要使零件易于分离。这只需令锥套取最佳角度(8°)即可达到目的。

如下图1、图2简要解释锥套配合受力情况。当轴向力(F)迫使锥套推入轮毂内时，在轴和锥套、锥套和轮毂的界面上产生径向力(P_s)和(P_h)，这些压力可达到 $70-80N/mm^2$ ($P_h > P_s$)。在轮毂、锥套的锥面上产生周向拉应力及周向压力，其值可达 $160-190N/mm^2$ 。在皮带轮与锥套配套设计中，皮带轮和锥套的配合是确定的，锥套轴孔径必须在允许的最大轴孔径以内(参见P17、P18页)。



图1



图2

◆使用优点

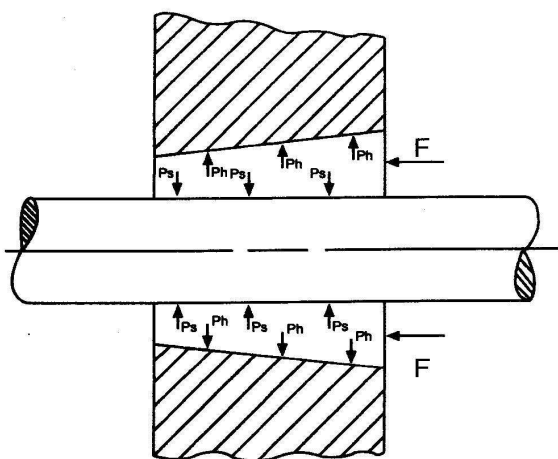
- * 安装 / 拆卸只需1支英制六角扳手，无需其它任何专用工具，方便快捷(只需大约1分钟便可完成)。
- * 皮带轮和锥套的分离，使得轴孔的改变只需改变锥套孔径，增加了产品通用性，大大降低了产品的库存种类和成本。
- * 其传动的可靠性，在全世界数以百万计的使用中得到证明。

- * 允许较宽的轴径公差： $+0.05mm \sim -0.125mm$ ($0.002'' \text{ to } -0.005''$)。
- * 轻 / 中轻程度负载允许无键传动。
- * 严格按国际标准 DIN2211 生产，全部产品经平衡测试及表面防锈处理。

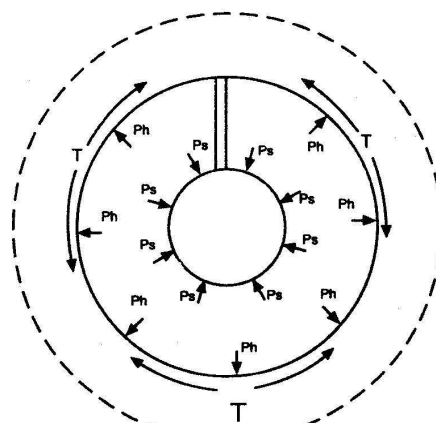

广州西冠机电设备有限公司

V形带皮带轮型号说明

SPB 250 - 2 - 2517



V形带皮带轮外形尺寸

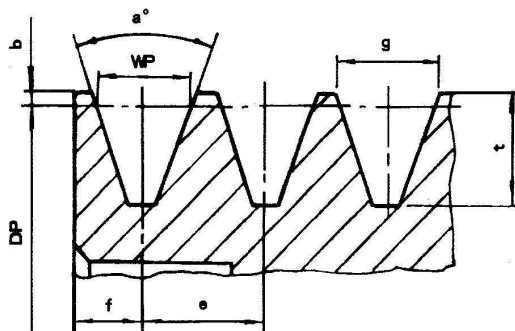

V形带轮槽形种类

槽形	wp	b	t	e	f	DP	角度 a°	g
SPZ	8.5	2.0	11.0 ^{+0.60} ₀	12 ± 0.3	8.0 ± 0.6	≤80	34 ± 1	9.7
						>80	38 ± 1	
SPA	11.0	2.8	13.8 ^{+0.60} ₀	15 ± 0.3	10.0 ± 0.6	≤118	34 ± 1	12.7
						>118	38 ± 1	
SPB	14.0	3.5	17.5 ^{+0.60} ₀	19 ± 0.4	12.5 ± 0.8	≤190	34 ± 1	16.3
						>190	38 ± 1	
SPC	19.0	4.8	23.8 ^{+0.60} ₀	25.5 ± 0.5	17.0 ± 1	≤315	34 ± 0.5	22
						>315	38 ± 0.5	



广州西冠机电设备有限公司

SPZ-1

皮带轮型号	锥套型号	重量	图例	F	R	L	P
SPZ60-1	1008	0.35	2	22		22	
SPZ63-1	1108	0.35	4	16		22	6
SPZ67-1	1108	0.35	4	16		22	6
SPZ71-1	1108	0.4	4	16		22	6
SPZ75-1	1108	0.65	4	16		22	6
SPZ80-1	1210	0.55	4	16		25	9
SPZ85-1	1210	0.6	4	16		25	9
SPZ90-1	1210	0.7	4	16		25	9
SPZ95-1	1210	0.7	4	16		25	9
SPZ100-1	1210	0.9	4	16		25	9
SPZ106-1	1610	1	4	16		25	9
SPZ112-1	1610	1.1	4	16		25	9
SPZ118-1	1610	1.3	4	16		25	9
SPZ125-1	1610	1.4	4	16		25	9
SPZ132-1	1610	1.45	4	16		25	9
SPZ140-1	1610	1.3	4	16		25	9
SPZ150-1	1610	1.5	4	16		25	9
SPZ160-1	1610	1.7	4	16		25	9
SPZ170-1	1610	1.8	4	16		25	9
SPZ180-1	1610	2	8	16		25	9
SPZ190-1	1610	2.3	8	16		25	9
SPZ200-1	2012	2.55	8	16		32	16
SPZ212-1	2012	2.65	8	16		32	16
SPZ224-1	2012	2.8	8	16		32	16
SPZ250-1	2012	3.2	11	16		32	8
SPZ280-1	2012	3.7	10	16		32	8
SPZ315-1	2012	3.5	10	16		32	8
SPZ355-1	2012	4	11	16		32	8
SPZ400-1	2012	6	11	16		32	8

SPZ-2

皮带轮型号	锥套型号	重量	图例	F	R	L	P
SPZ60-2	1108	0.4	3	49	27	22	
SPZ63-2	1108	0.4	5	28	6	22	
SPZ67-2	1108	0.4	5	28	6	22	
SPZ71-2	1108	0.45	5	28	6	22	
SPZ75-2	1210	0.5	5	28	3	25	
SPZ80-2	1210	0.55	5	28	3	25	
SPZ85-2	1610	0.55	5	28	3	25	
SPZ90-2	1610	0.6	5	28	3	25	
SPZ95-2	1610	0.8	5	28	3	25	
SPZ100-2	1610	1.15	5	28	3	25	
SPZ106-2	1610	1.2	5	28	3	25	
SPZ112-2	1610	1.3	5	28	3	25	
SPZ118-2	1610	1.4	5	28	3	25	
SPZ125-2	1610	1.7	5	28	3	25	
SPZ132-2	1610	2	5	28	3	25	
SPZ140-2	1610	2.2	5	28	3	25	4
SPZ150-2	2012	2.3	5	28		32	4
SPZ160-2	2012	2.45	4	28		32	4
SPZ170-2	2012	2.65	4	28		32	4
SPZ180-2	2012	2.9	4	28		32	4
SPZ190-2	2012	3.2	8	28		32	4
SPZ200-2	2012	3.5	8	28		32	4
SPZ212-2	2012	3.5	8	28		32	4
SPZ224-2	2012	3.4	8	28		32	4
SPZ250-2	2012	3.9	80	28		32	2
SPZ280-2	2012	4.9	11	28		32	2
SPZ315-2	2012	5.8	11	28		32	2
SPZ355-2	2012	6.3	11	28		32	2
SPZ400-2	2517	7.1	11	28		45	8.5
SPZ500-2	2517	9.1	11	40		45	8.5



广州西冠机电设备有限公司

SPZ-3

皮带轮型号	锥套型号	重量	图例	F	R	L	P
SPZ63-3	1108	0.45	5	40	18	22	
SPZ67-3	1108	0.5	5	40	18	22	
SPZ71-3	1108	0.7	5	40	18	22	
SPZ75-3	1210	0.75	5	40	15	25	
SPZ80-3	1210	0.75	5	40	15	25	
SPZ85-3	1610	0.8	5	40	15	25	
SPZ90-3	1610	0.85	5	40	15	25	
SPZ95-3	1610	1.05	5	40	15	25	
SPZ100-3	1610	1.2	5	40	15	25	
SPZ106-3	1610	1.35	5	40	15	25	
SPZ112-3	2012	1.35	5	40	8	32	
SPZ118-3	2012	1.6	5	40	8	32	
SPZ125-3	2012	2	6	40	8	32	
SPZ132-3	2012	2.4	6	40	8	32	
SPZ140-3	2012	2.8	6	40	8	32	
SPZ150-3	2012	3.4	6	40	8	32	
SPZ160-3	2012	3.4	6	40	8	32	
SPZ170-3	2012	3.5	7	40	4	32	
SPZ180-3	2012	3.6	15	40	8	32	
SPZ190-3	2012	3.65	9	40	4	32	
SPZ200-3	2012	3.8	9	40	4	32	
SPZ212-3	2012	4.2	9	40	4	32	
SPZ224-3	2012	4.7	9	40	4	32	
SPZ250-3	2012	4.9	12	40	4	32	
SPZ280-3	2517	7.8	11	40		45	2.5
SPZ315-3	2517	8.3	11	40		45	2.5
SPZ355-3	2517	8.9	11	40		45	2.5
SPZ400-3	2517	9.5	11	40		45	2.5
SPZ450-3	2517	10.8	11	40		45	2.5
SPZ500-3	2517	12	11	40		45	2.5
SPZ560-3	2517	13.8	13	40		45	5

SPZ-4

皮带轮型号	锥套型号	重量	图例	F	R	L	P
SPZ63-4	1108	0.6	5	52	30	22	
SPZ67-4	1108	0.66	5	52	30	22	
SPZ71-4	1108	0.78	5	52	30	22	
SPZ75-4	1210	0.85	5	52	27	25	
SPZ80-4	1210	0.85	5	52	27	25	
SPZ85-4	1610	0.95	5	52	27	25	
SPZ90-4	1610	1	5	52	27	25	
SPZ95-4	1610	1.15	5	52	27	25	
SPZ100-4	1610	1.3	5	52	27	25	
SPZ106-4	1610	1.4	5	52	27	25	
SPZ112-4	2012	1.6	5	52	20	32	
SPZ118-4	2012	1.9	5	52	20	32	
SPZ125-4	2012	2.2	6	52	20	32	
SPZ132-4	2012	2.6	6	52	20	32	
SPZ140-4	2012	3	6	52	20	32	
SPZ150-4	2517	3.6	6	52	7	45	
SPZ160-4	2517	4.5	6	52	7	45	
SPZ170-4	2517	4.85	6	52	7	45	
SPZ180-4	2517	5.1	6	52	7	45	
SPZ190-4	2517	5.2	7	52	3.5	45	
SPZ200-4	2517	5.5	9	52	3.5	45	
SPZ212-4	2517	5.9	9	52	3.5	45	
SPZ224-4	2517	6.2	9	52	3.5	45	
SPZ250-4	2517	6.6	9	52	3.5	45	
SPZ280-4	2517	7.2	9	52	3.5	45	
SPZ315-4	2517	8.5	12	52	3.5	45	
SPZ355-4	2517	9.4	12	52	3.5	45	
SPZ400-4	2517	11.2	12	52	3.5	45	
SPZ450-4	3020	13.8	12	52	0.5	51	



广州西冠机电设备有限公司

SPZ-5

皮带轮型号	锥套型号	重量	图例	F	R	L	P
SPZ85-5	1610	1.3	5	64	39	25	
SPZ90-5	1610	1.4	5	64	39	25	
SPZ95-5	1610	1.6	5	64	39	25	
SPZ100-5	2012	1.6	5	64	32	32	
SPZ106-5	2012	1.9	5	64	32	32	
SPZ112-5	2012	2.2	5	64	32	32	
SPZ118-5	2012	2.3	5	64	32	32	
SPZ125-5	2012	2.7	5	64	32	32	
SPZ132-5	2517	3.2	5	64	19	45	
SPZ140-5	2517	3.5	6	64	19	45	
SPZ150-5	2517	4.3	6	64	19	45	
SPZ160-5	2517	5.1	6	64	19	45	
SPZ170-5	2517	5.8	6	64	19	45	
SPZ180-5	2517	6.9	6	64	19	45	
SPZ190-5	2517	6.5	7	64	9.5	45	
SPZ200-5	2517	6.1	7	64	9.5	45	
SPZ212-5	2517	6.6	9	64	9.5	45	
SPZ224-5	2517	7	9	64	9.5	45	
SPZ250-5	2517	8.1	9	64	9.5	45	
SPZ280-5	2517	9.8	9	64	9.5	45	
SPZ315-5	2517	11	12	64	9.5	45	
SPZ355-5	2517	13.2	12	64	6.5	45	
SPZ400-5	3020	14.5	12	64	6.5	51	
SPZ450-5	3020	16.3	12	64	6.5	51	
SPZ500-5	3030	18.5	11	64		76	6

SPZ-6

皮带轮型号	锥套型号	重量	图例	F	R	L	P
SPZ90-6	1610	1.68	5	76	51	25	
SPZ95-6	1610	1.85	5	76	51	25	
SPZ100-6	2012	1.9	5	76	44	32	
SPZ106-6	2012	2.2	5	76	44	32	
SPZ112-6	2012	2.5	5	76	44	32	
SPZ118-6	2517	2.5	5	76	31	45	
SPZ125-6	2517	3	5	76	31	45	
SPZ132-6	2517	3.5	5	76	31	45	
SPZ140-6	2517	3.9	6	76	31	45	
SPZ150-6	2517	4.7	6	76	31	45	
SPZ160-6	2517	5.5	6	76	31	45	
SPZ170-6	2517	6.8	6	76	31	45	
SPZ180-6	2517	7.3	7	76	16	45	
SPZ190-6	2517	7.5	7	76	15.5	45	
SPZ200-6	2517	6.6	7	76	16	45	
SPZ212-6	2517	7.5	9	76	15.5	45	
SPZ224-6	2517	7.6	9	76	15.5	45	
SPZ250-6	2517	8.9	9	76	15.5	45	
SPZ280-6	2517	10.8	9	76	15.5	45	
SPZ315-6	2517	12.2	9	76	15.5	45	
SPZ355-6	2517	14.6	12	76	15.5	45	
SPZ400-6	3030	15.9	11	76	15.5	76	



广州西冠机电设备有限公司

SPA-1

皮带轮型号	锥套型号	重量	图例	F	R	L	P
SPA63-1	1008	0.4	4	22		22	2
SPA67-1	1108	0.4	4	22		22	2
SPA71-1	1108	0.4	4	22		22	2
SPA75-1	1108	0.5	4	22		22	2
SPA80-1	1210	0.5	4	22		25	5
SPA85-1	1210	0.6	4	22		25	5
SPA90-1	1210	0.7	4	22		25	5
SPA95-1	1210	0.8	4	22		25	5
SPA100-1	1610	0.85	4	22		25	5
SPA106-1	1610	1	4	22		25	5
SPA112-1	1610	1.15	4	22		25	5
SPA118-1	1610	1.25	4	22		25	5
SPA125-1	1610	1.4	4	22		25	5
SPA132-1	1610	1.5	4	22		25	5
SPA140-1	1610	1.6	4	22		25	5
SPA150-1	1610	1.7	4	22		25	5
SPA160-1	1610	1.9	4	22		25	5
SPA170-1	1610	2	4	22		25	5
SPA180-1	1610	2	8	22		25	5
SPA190-1	1610	2.7	8	22		25	5
SPA200-1	2012	2.8	8	22		32	12
SPA212-1	2012	2.9	8	22		32	12
SPA224-1	2012	3	8	22		32	12
SPA236-1	2012	3.2	8	22		32	12
SPA250-1	2012	3.6	11	22		32	6
SPA280-1	2012	4.2	8	22		32	12
SPA300-1	2012	4.3	8	22		32	12
SPA315-1	2012	4.4	8	22		32	12
SPA355-1	2012	6.1	13	22		32	12

SPA-2

皮带轮型号	锥套型号	重量	图例	F	R	L	P
SPA80-2	1210	0.65	5	35	10	25	
SPA85-2	1210	0.7	5	35	10	25	
SPA90-2	1610	0.75	5	35	10	25	
SPA95-2	1610	0.8	5	35	10	25	
SPA100-2	1610	0.95	5	35	10	25	
SPA106-2	1610	1.2	5	35	10	25	
SPA112-2	1610	1.4	5	35	10	25	
SPA118-2	1610	1.7	5	35	10	25	
SPA125-2	1610	1.9	5	35	10	25	
SPA132-2	2012	2.1	5	35	3	32	
SPA140-2	2012	2.6	5	35	3	32	
SPA150-2	2012	3.2	5	35	3	32	
SPA160-2	2012	3.7	5	35	3	32	
SPA170-2	2012	3.8	5	35	3	32	
SPA180-2	2012	3.4	9	35	2	32	
SPA190-2	2012	4.3	15	35	3	32	
SPA200-2	2517	4.5	10	35		45	5
SPA212-2	2517	4.7	8	35		45	10
SPA224-2	2517	5	8	35		45	10
SPA236-2	2517	5.4	8	35		45	10
SPA250-2	2517	5.6	11	35		45	5
SPA280-2	2517	6.8	8	35		45	10
SPA300-2	2517	6.9	8	35		45	10
SPA315-2	2517	7.2	8	35		45	10
SPA355-2	2517	9.4	13	35		45	10
SPA400-2	2517	10	13	35		45	10
SPA450-2	2517	11	13	35		45	10
SPA500-2	2517	12.5	13	35		45	10
SPA630-2	3020	20.5	11	35		51	10
SPA800-2	3535	28	11	35		65	10



广州西冠机电设备有限公司

SPA-3

皮带轮型号	锥套型号	重量	图例	F	R	L	P
SPA80-3	1210	1	5	50	25	25	
SPA85-3	1210	1	5	50	25	25	
SPA90-3	1610	1	5	50	25	25	
SPA95-3	1610	1.2	5	50	25	25	
SPA100-3	1610	1.3	6	50	25	25	
SPA106-3	1610	1.4	6	50	25	25	
SPA112-3	2012	1.5	5	50	18	32	
SPA118-3	2012	1.9	6	50	18	32	
SPA125-3	2012	2.2	6	50	18	32	
SPA132-3	2012	2.5	6	50	18	32	
SPA140-3	2517	2.8	5	50	5	45	
SPA150-3	2517	3.5	5	50	5	45	
SPA160-3	2517	4.1	5	50	5	45	
SPA170-3	2517	4.5	5	50	5	45	
SPA180-3	2517	5.1	5	50	5	45	
SPA190-3	2517	5.5	5	50	5	45	
SPA200-3	2517	5.8	9	50	2.5	45	
SPA212-3	2517	6	9	50	2.5	45	
SPA224-3	2517	6.3	9	50	2.5	45	
SPA236-3	2517	6.6	9	50	2.5	45	
SPA250-3	2517	6.7	9	50	2.5	45	
SPA280-3	2517	8	9	50	2.5	45	
SPA300-3	3020	9.3	8	50		51	
SPA315-3	3020	10.6	8	50		51	1
SPA355-3	3020	11.5	11	50		51	0.5
SPA400-3	3020	14.2	13	50		51	1
SPA450-3	3020	15.3	13	50		51	1
SPA500-3	3020	15.5	13	50		51	1
SPA560-3	3020	16	13	50		51	1

SPA-4

皮带轮型号	锥套型号	重量	图例	F	R	L	P
SPA90-4	1615	1.2	5	65	27	38	
SPA95-4	1615	1.6	5	65	27	38	
SPA100-4	1615	1.8	6	65	27	38	
SPA106-4	2012	2.15	5	65	33	32	
SPA112-4	2012	2.6	5	65	33	32	
SPA118-4	2012	2.7	6	65	33	32	
SPA125-4	2012	2.8	6	65	33	32	
SPA132-4	2517	3.2	6	65	20	32	
SPA140-4	2517	3.3	6	65	20	45	
SPA150-4	2517	3.9	6	65	20	45	
SPA160-4	2517	4.8	6	65	20	45	
SPA170-4	2517	6.2	6	65	20	45	
SPA180-4	2517	6.8	6	65	20	45	
SPA190-4	2517	7.2	6	65	20	45	
SPA200-4	3020	7.9	6	65	14	45	
SPA212-4	3020	8.5	6	65	14	51	
SPA224-4	3020	8.8	6	65	14	51	
SPA236-4	3020	9.8	9	65	7	51	
SPA250-4	3020	10.7	9	65	7	51	
SPA280-4	3020	12.1	9	65	7	51	
SPA300-4	3020	12.4	9	65	7	51	
SPA315-4	3020	12.9	9	65	7	51	
SPA355-4	3020	12	12	65	7	51	
SPA400-4	3020	14	12	65	7	51	
SPA450-4	3020	15.8	12	65	7	51	
SPA500-4	3020	18.7	12	65	7	51	
SPA560-4	3535	23.5	11	65	7	89	12
SPA630-4	3535	28	11	65	7	89	12



广州西冠机电设备有限公司

SPA-5

皮带轮型号	锥套型号	重量	图例	F	R	L	P
SPA90-5	1615	1.9	5	80	42	38	
SPA95-5	1615	2	5	80	42	38	
SPA100-5	1615	2.1	6	80	42	38	
SPA106-5	2012	2.2	5	80	48	32	
SPA112-5	2012	2.3	5	80	48	32	
SPA118-5	2012	2.6	6	80	48	32	
SPA125-5	2012	3	7	80	24	32	
SPA132-5	2517	3.2	7	80	17.5	45	
SPA140-5	2517	3.9	7	80	17.5	45	
SPA150-5	2517	4.4	7	80	17.5	45	
SPA160-5	2517	5.7	7	80	17.5	45	
SPA170-5	2517	6.2	7	80	17.5	45	
SPA180-5	3020	6.9	7	80	14.5	51	
SPA190-5	3020	7.7	6	80	29	51	
SPA200-5	3020	9.4	7	80	14.5	51	
SPA212-5	3020	9.8	6	80	29	51	
SPA224-5	3020	10.2	6	80	29	51	
SPA236-5	3020	12.2	9	80	14.5	51	
SPA250-5	3020	12.4	9	80	14.5	51	
SPA280-5	3535	15	10	80		89	4.5
SPA300-5	3535	16.5	8	80		89	9
SPA315-5	3535	18.5	10	80		89	4.5
SPA355-5	3535	20	11	80		89	4.5
SPA400-5	3535	21.5	11	80		89	4.5
SPA450-5	3535	23	11	80		89	4.5
SPA500-5	3535	26.5	11	80		89	4.5
SPA560-5	3535	30.4	11	80		89	4.5
SPA630-5	3535	34.5	11	80		89	4.5

SPA-6

皮带轮型号	锥套型号	重量	图例	F	R	L	P
SPA100-6	1610	2.4	7	95	40	25	
SPA106-6	2012	2.6	5	95	63	32	
SPA112-6	2012	2.7	5	95	63	32	
SPA118-6	2012	2.9	5	95	63	32	
SPA125-6	2012	3.2	7	95	32	32	
SPA132-6	2517	3.8	7	95	25	45	
SPA140-6	2517	4.1	7	95	25	45	
SPA150-6	2517	4.9	7	95	25	45	
SPA160-6	2517	5.7	7	95	25	45	
SPA170-6	2517	6	7	95	25	45	
SPA180-6	3020	7	7	95	22	51	
SPA190-6	3020	8	7	95	22	51	
SPA200-6	3020	9.6	7	95	22	51	
SPA212-6	3020	10	7	95	22	51	
SPA224-6	3020	10.6	7	95	22	51	
SPA236-6	3020	12	9	95	22	51	
SPA250-6	3020	13	9	95	22	51	
SPA280-6	3535	19.1	9	95	3	89	
SPA315-6	3535	25	9	95	3	89	
SPA355-6	3535	25	12	95	3	89	
SPA400-6	3535	25.2	12	95	3	89	
SPA450-6	3535	40	12	95	3	89	
SPA500-6	3535	54.2	12	95		89	
SPA630-6	4040	56	11	95		102	3.5
SPA800-6	4040	60	11	95		102	3.5



广州西冠机电设备有限公司

SPB-1

皮带轮型号	锥套型号	重量	图例	F	R	L	P
SPB100-1	1610	0.9	2	25		25	
SPB106-1	1610	1.1	2	25		25	
SPB112-1	1610	1.2	2	25		25	
SPB118-1	1610	1.3	2	25		25	
SPB125-1	1610	1.5	2	25		25	
SPB132-1	1610	1.7	2	25		25	
SPB140-1	1610	1.8	2	25		25	
SPB150-1	1610	2.1	2	25		25	
SPB160-1	1610	2.5	2	25		25	
SPB170-1	1610	2.9	2	25		25	
SPB180-1	1610	3.2	2	25		25	
SPB190-1	2012	3.8	10	25		32	3.5
SPB200-1	2012	4.2	10	25		32	3.5
SPB212-1	2012	4.3	10	25		32	3.5
SPB224-1	2012	4.7	10	25		32	3.5
SPB236-1	2012	5.1	10	25		32	3.5
SPB250-1	2012	5.7	10	25		32	3.5
SPB280-1	2012	6	10	25		32	3.5
SPB300-1	2012	7.1	8	25		32	7
SPB315-1	2012	7.5	10	25		32	3.5

SPB-2

皮带轮型号	锥套型号	重量	图例	F	R	L	P
SPB95-2	1210	1.2	5	44	19	25	
SPB100-2	1610	1.4	5	44	19	25	
SPB106-2	1610	1.6	5	44	19	25	
SPB112-2	1610	1.7	5	44	19	25	
SPB118-2	1610	1.9	6	44	19	25	
SPB125-2	2012	1.9	6	44	12	32	
SPB132-2	2012	2.2	6	44	12	32	
SPB140-2	2012	2.7	6	44	12	32	
SPB150-2	2012	3.2	6	44	12	32	
SPB160-2	2012	3.3	6	44	12	32	
SPB170-2	2012	3.5	6	44	12	32	
SPB180-2	2517	3.9	4	44	18	45	1
SPB190-2	2517	4.6	4	44	18	45	1
SPB200-2	2517	5.1	4	44	18	45	1
SPB212-2	2517	5.5	8	44	18	45	1
SPB224-2	2517	5.9	8	44	18	45	1
SPB236-2	2517	6.6	8	44		45	1
SPB250-2	2517	6.8	8	44		45	1
SPB280-2	2517	7.5	8	44		45	1
SPB300-2	2517	8.5	8	44		45	1
SPB315-2	2517	9.5	8	44		45	1
SPB335-2	2517	11.3	8	44		45	1
SPB355-2	3020	12	10	44		45	3.5
SPB375-2	3020	19.4	10	44		51	3.5
SPB400-2	3020	14	11	44		51	3.5
SPB450-2	3020	12	11	44		51	3.5
SPB500-2	3020	13.5	11	44		51	3.5
SPB560-2	3030	25	1	44		51	28.5
SPB630-2	3030	29.3	11	44		51	16



广州西冠机电设备有限公司

SPB-3

皮带轮型号	锥套型号	重量	图例	F	R	L	P
SPB100-3	1610	1.9	5	63	38	25	13
SPB106-3	1610	2.2	5	63	38	25	26
SPB112-3	1610	2.3	5	63	38	25	26
SPB118-3	1610	2.6	6	63	38	25	26
SPB125-3	2012	2.7	6	63	31	32	26
SPB132-3	2012	2.8	6	63	31	32	13
SPB140-3	2012	3.5	6	63	31	32	
SPB150-3	2517	4	6	63	18	45	
SPB160-3	2517	4.5	6	63	18	45	
SPB170-3	2517	5.3	6	63	18	45	
SPB180-3	2517	6	6	63	18	45	
SPB190-3	2517	6.6	6	63	18	45	
SPB200-3	2517	7	6	63	18	45	
SPB212-3	2517	6.9	15	63	18	45	
SPB224-3	2517	6.9	15	63	18	45	
SPB236-3	2517	8.8	15	63	18	45	
SPB250-3	3020	9	15	63	12	51	
SPB280-3	3020	9.3	9	63	6	51	
SPB300-3	3020	9.8	9	63	6	51	
SPB315-3	3020	9.8	9	63	6	51	
SPB335-3	3020	10	9	63	6	51	
SPB355-3	3020	12	9	63	6	51	
SPB400-3	3020	22.5	11	63		89	
SPB450-3	3020	23.5	13	63		89	
SPB500-3	3020	24	13	63		89	
SPB560-3	3020	30	13	63		89	
SPB630-3	3020	30.3	13	63		89	
SPB710-3	3020	35	11	63		89	

SPB-4

皮带轮型号	锥套型号	重量	图例	F	R	L	P
SPB125-4	2012	3.5	7	82	25	32	
SPB132-4	2012	3.7	7	82	25	32	
SPB140-4	2517	3.9	7	82	18.5	45	
SPB150-4	2517	4.5	7	82	19	45	
SPB160-4	2517	5.2	7	82	19	45	
SPB170-4	2517	6	7	82	18.5	45	
SPB180-4	2517	7	7	82	19	45	
SPB190-4	2517	8	7	82	18.5	45	
SPB200-4	3020	9	7	82	16	51	
SPB212-4	3020	10	7	82	15.5	51	
SPB224-4	3020	11.5	7	82	16	51	
SPB236-4	3020	14	7	82	15.5	51	
SPB250-4	3020	12	9	82	16	51	
SPB280-4	3020	13.5	9	82		89	7
SPB300-4	3535	14.6	8	82		89	3.5
SPB315-4	3535	17.5	10	82		89	3.5
SPB335-4	3535	18.4	10	82		89	3.5
SPB355-4	3535	19.2	10	82		89	3.5
SPB375-4	3535	20.6	10	82		89	3.5
SPB400-4	3535	21	11	82		89	7
SPB450-4	3535	25	13	82		89	7
SPB500-4	3535	27	13	82		89	7
SPB560-4	3535	33	13	82		89	7
SPB630-4	3535	36	13	82		89	7
SPB710-4	3535	41	11	82		89	3.5
SPB800-4	4040	48	11	82		102	10



广州西冠机电设备有限公司

SPB-5

皮带轮型号	锥套型号	重量	图例	F	R	L	P
SPB125-5	2012	4.4	5	101	69	32	
SPB132-5	2517	4.6	7	101	56	45	
SPB140-5	2517	4.8	7	101	28	45	
SPB150-5	2517	5.4	7	101	28	45	
SPB160-5	2517	6.2	7	101	28	45	
SPB170-5	3020	6.5	7	101	25	51	
SPB180-5	3020	7.5	7	101	25	51	
SPB190-5	3020	8.5	7	101	25	51	
SPB200-5	3020	9.6	7	101	25	51	
SPB212-5	3020	11.5	7	101	25	51	
SPB224-5	3020	13	7	101	25	51	
SPB236-5	3535	19.2	7	101	6	89	
SPB250-5	3535	22	7	101	6	89	
SPB280-5	3535	18.5	9	101	6	89	
SPB300-5	3535	19	9	101	6	89	
SPB315-5	3535	19.5	9	101	6	89	
SPB335-5	3535	19.6	9	101	6	89	
SPB355-5	3535	21.5	9	101	6	89	
SPB400-5	3535	24.5	12	101	6	89	
SPB450-5	3535	29	16	101	6	89	
SPB500-5	3535	31	16	101	12	89	
SPB560-5	4040	36	13	101	12	89	
SPB630-5	4040	48.5	13	101		102	1
SPB710-5	4040	52.5	13	101		102	1
SPB800-5	4040	56	13	101		102	1
SPB900-5	4040	114	13	101		102	1
SPB1000-5	4045	93	11	101		114	6.5

SPB-6

皮带轮型号	锥套型号	重量	图例	F	R	L	P
SPB140-6	2517	4.8	7	120	37.5	45	
SPB150-6	2517	5.9	7	120	37.5	45	
SPB160-6	3020	6.2	7	120	34.5	51	
SPB170-6	3020	6.8	7	120	35	51	
SPB180-6	3020	8.2	7	120	35	51	
SPB190-6	3020	9.7	7	120	34.5	51	
SPB200-6	3020	10.5	7	120	35	51	
SPB212-6	3535	14.5	7	120	15.5	89	
SPB224-6	3535	17.5	7	120	16	89	
SPB236-6	3535	21	7	120	15.5	89	
SPB250-6	3535	23.5	7	120	16	89	
SPB280-6	3535	20	9	120	15.5	89	
SPB300-6	3535	22	9	120	16	89	
SPB315-6	3535	24	9	120	15.5	89	
SPB335-6	3535	22	9	120	16	89	
SPB355-6	3535	23.5	9	120	15.5	89	
SPB400-6	3535	26.5	12	120	15.5	89	
SPB450-6	4040	36.5	16	120	18	102	
SPB500-6	4040	40	16	120	18	102	
SPB560-6	4040	55	16	120	18	102	
SPB630-6	4040	49	16	120	18	102	
SPB710-6	4040	62	12	120	9	102	
SPB800-6	4545	66	12	120	3	114	
SPB900-6	4545	120	12	120	3	114	
SPB1000-6	4545	100	12	120	3	114	



广州西冠机电设备有限公司

SPB-8

皮带轮型号	锥套型号	重量	图例	F	R	L	P
SPB180-8	3030	11.5	7	158	41	76	
SPB190-8	3030	13	7	158	41	76	
SPB200-8	3535	14	7	158	34.5	89	
SPB212-8	3535	17	7	158	34.5	89	
SPB224-8	3535	19.5	7	158	34.5	89	
SPB236-8	3535	23	7	158	34.5	89	
SPB250-8	3535	26.5	7	158	34.5	89	
SPB280-8	3535	28	9	158	34.5	89	
SPB300-8	3535	30	9	158	34.5	89	
SPB315-8	3535	27	9	158	34.5	89	
SPB335-8	3535	28.5	9	158	34.5	89	
SPB355-8	3535	30	9	158	34.5	89	
SPB400-8	4040	37	9	158	28.5	102	
SPB450-8	4040	42	12	158	28	102	
SPB475-8	4040	46	12	158	28	102	
SPB500-8	4040	47	12	158	28	102	
SPB560-8	4545	60	12	158	22	114	
SPB630-8	4545	64	12	158	22	114	
SPB710-8	4545	72	12	158	22	114	
SPB800-8	4545	92	12	158	22	114	
SPB900-8	4545	132	12	158	22	114	
SPB1000-8	5050	140	12	158	15.5	127	

SPC-3

皮带轮型号	锥套型号	重量	图例	F	R	L	P
SPC200-3	2517	10.25	7	85	20	45	
SPC212-3	3020	11	7	85	17	51	
SPC224-3	3020	12	7	85	17	51	
SPC236-3	3020	13	7	85	17	51	
SPC250-3	3020	15.5	7	85	17	51	
SPC265-3	3535	22	4	85		89	4
SPC280-3	3535	25	4	85		89	4
SPC300-3	3535	22	10	85		89	2
SPC315-3	3535	22.5	10	85		89	2
SPC335-3	3535	23.5	10	85		89	2
SPC355-3	3535	24	10	85		89	2
SPC375-3	3535	25	10	85	10	89	2
SPC400-3	3535	25	10	85	10	89	2
SPC425-3	3535	27	10	85	10	89	2
SPC450-3	3535	30	11	85	11	89	2
SPC475-3	3535	31	11	85	11	89	2
SPC500-3	3535	32	11	85	11	89	2
SPC530-3	3535	35.6	11	85	11	89	2
SPC560-3	3535	37	11	85	11	89	2
SPC630-3	4040	50.0	11	85	11	102	8.5
SPC800-3	4545	75	11	85	11	114	14.5
SPC1000-3	5050	86	11	85	11	127	21



广州西冠机电设备有限公司

SPC-4

皮带轮型号	锥套型号	重量	图例	F	R	L	P
SPC200-4	3020	11.5	7	110.5	29.5	51	
SPC212-4	3020	13.5	7	110.5	29.5	51	
SPC224-4	3535	15	7	110.5	10.5	89	
SPC236-4	3535	18	7	110.5	10.5	89	
SPC250-4	3535	22	7	110.5	10.5	89	
SPC265-4	3535	25	7	110.5	10.5	89	
SPC280-4	3535	26	9	110.5	10.5	89	
SPC300-4	3535	26	9	110.5	10.5	89	
SPC315-4	3535	26	9	110.5	10.5	89	
SPC335-4	3535	27.5	9	110.5	10.5	89	
SPC355-4	3535	29	9	110.5	10.5	89	
SPC375-4	3535	31	9	110.5	10.5	89	
SPC400-4	3535	29	9	110.5	10.5	89	
SPC425-4	3535	32	9	110.5	10.5	89	
SPC450-4	3535	34.5	12	110.5	10.5	89	
SPC475-4	3535	37.5	12	110.5	10.5	89	
SPC500-4	3535	40	12	110.5	10.5	89	
SPC530-4	4040	45.8	12	110.5	4.5	102	
SPC560-4	4040	50	12	110.5	4.5	102	51
SPC630-4	4545	61	11	110.5		114	2
SPC800-4	5050	89	11	110.5		127	8.5
SPC1000-4	5050	114	11	110.5		127	8.5

SPC-5

皮带轮型号	锥套型号	重量	图例	F	R	L	P
SPC200-5	3535	10.5	7	136	23.5	89	
SPC212-5	3535	14.5	7	136	23.5	89	
SPC224-5	3535	17	7	136	23.5	89	
SPC236-5	3535	20.5	7	136	24	89	
SPC250-5	3535	23.5	7	136	24	89	
SPC265-5	3535	27.5	7	136	23.5	89	
SPC280-5	3535	32	7	136	23.5	89	
SPC300-5	3535	29	9	136	23.5	89	
SPC315-5	3535	30	9	136	23.5	89	
SPC335-5	3535	31	9	136	23.5	89	
SPC355-5	3535	33.5	9	136	23.5	89	
SPC375-5	3535	34	9	136	23.5	89	
SPC400-5	3535	35	9	136	24	89	
SPC425-5	3535	46	9	136	23.5	89	
SPC450-5	4040	46	12	136	17	102	
SPC475-5	4040	47.5	12	136	17	102	
SPC500-5	4040	49.5	12	136	17	102	
SPC530-5	4545	56.5	12	136	11	114	
SPC560-5	4545	61	12	136	11	114	
SPC630-5	5050	78	12	136	4.5	127	
SPC710-5	5050	89	12	136	5	127	
SPC800-5	5050	96.5	12	136	4.5	127	
SPC1000-5	5050	143	12	136	4.5	127	

广州西冠机电设备有限公司

SPC-6

皮带轮型号	锥套型号	重量	图例	F	R	L	P
SPC200-6	3535	12.6	7	161.5	36.5	89	
SPC212-6	3535	17.4	7	161.5	36.5	89	
SPC224-6	3535	20	7	161.5	36.5	89	
SPC236-6	3535	21.5	7	161.5	36.5	89	
SPC250-6	3535	27	7	161.5	36.5	89	
SPC265-6	3535	30	7	161.5	36.5	89	
SPC280-6	3535	35	9	161.5	36.5	89	
SPC300-6	3535	30	9	161.5	36.5	89	
SPC315-6	3535	32.5	9	161.5	36.5	89	
SPC335-6	3535	36	9	161.5	36.5	89	
SPC355-6	3535	37	9	161.5	36.5	89	
SPC375-6	4040	46.5	9	161.5	29.5	102	
SPC400-6	4040	48.5	9	161.5	29.5	102	
SPC425-6	4040	59.5	9	161.5	29.5	102	
SPC450-6	4545	62.5	9	161.5	23.5	114	
SPC475-6	4545	66	9	161.5	23.5	114	
SPC500-6	4545	67.5	12	161.5	23.5	114	
SPC530-6	5050	73	12	161.5	17.5	127	
SPC560-6	5050	78.5	12	161.5	17.5	127	
SPC630-6	5050	87	12	161.5	17.5	127	
SPC710-6	5050	99.5	12	161.5	17.5	127	
SPC800-6	5050	126.5	12	161.5	17	127	
SPC1000-6	5050	155	12	161.5	17	127	

SPC-8

皮带轮型号	锥套型号	重量	图例	F	R	L	P
SPC200-8	3535	16.5	7	212.5	61.5	89	
SPC212-8	3535	22	7	212.5	61.5	89	
SPC224-8	3535	26.5	7	212.5	61.5	89	
SPC236-8	3535	27	7	212.5	62	89	
SPC250-8	3535	30.5	7	212.5	62	89	
SPC265-8	3535	34.5	7	212.5	61.5	89	
SPC280-8	3535	38.5	7	212.5	61.5	89	
SPC300-8	4040	47.5	7	212.5	55.5	102	
SPC315-8	4040	51	7	212.5	55.5	102	
SPC335-8	4040	59.5	7	212.5	55.5	102	
SPC355-8	4040	68.5	7	212.5	55.5	102	
SPC375-8	4545	69	9	212.5	49.5	114	
SPC400-8	4545	65	9	212.5	50	114	
SPC425-8	4545	75	9	212.5	49.5	114	
SPC450-8	5050	89.5	9	212.5	43	127	
SPC475-8	5050	95.8	9	212.5	42.5	127	
SPC500-8	5050	102	12	212.5	43	127	
SPC530-8	5050	105	12	212.5	42.5	127	
SPC560-8	5050	109	12	212.5	43	127	
SPC630-8	5050	126	12	212.5	42.5	127	
SPC710-8	5050	135	12	212.5	43	127	
SPC800-8	5050	144.5	12	212.5	42.5	127	
SPC1000-8	5050	205	12	212.5	42.5	127	



广州西冠机电设备有限公司

锥套孔径和相应的键槽尺寸(公制)

锥套型号	孔径	锥套键槽 毫米(mm)
1008	10	3*1.4
	11, 12	4*1.8
	14, 16	5*2.3
	18, 19, 20, 22	6*2.8
	24, 25	8*2.0
1108	10	3*1.4
	11, 12	4*1.8
	14, 16	5*2.3
	18, 19, 20, 22	6*2.8
	24, 25	8*3.3
1210	11, 12	4*1.8
	14, 16	5*2.3
	18, 19, 20, 22	6*2.8
	24, 25, 28, 30	8*3.3
	32	10*3.3
1610	14, 16	5*2.3
	18, 19, 20, 22	6*2.8
	24, 25, 28, 30	8*3.3
1615	32, 35, 38	10*3.3
	40	12*3.3
	42	12*2.2
2012	18, 19, 20, 22	6*2.8
	24, 25, 28, 30	8*3.3
	32, 35, 38	10*3.3
	40, 42	12*3.3
2517	45, 48, 50	14*3.8
	20, 22	6*2.8
	24, 25, 28, 30	8*3.3
	32, 35, 38	10*3.3
2517	40, 42	12*3.3
	45, 48, 50	14*3.8
	55	16*3.3
	60	18*4.4

锥套型号	孔径	锥套键槽 毫米(mm)
3020	25, 28, 30	8*3.3
	32, 35, 38	10*3.3
	40, 42	12*3.3
3030	45, 48, 50	14*3.8
	55	16*4.3
	60, 65	18*4.4
3525	70, 75	20*4.9
	35, 38	10*3.3
	40, 42	12*3.3
3535	45, 48, 50	14*3.8
	55	16*4.3
	60, 65	18*4.4
	70, 75	20*4.9
4030	80, 85	22*5.4
	90	25*5.4
	40, 42	12*3.3
	45, 48, 50	14*3.8
4040	55	16*4.3
	60, 65	18*4.4
	70, 75	20*4.9
	80, 85	22*5.4
4030	90, 95	25*5.4
	100	28*6.4
	55	16*4.3
	60, 65	18*4.4
4040	70, 75	20*4.9
	80, 85	22*5.4
	90, 95	25*5.4
	100, 105, 110	28*6.4
4030	60, 65	18*4.4
	70, 75	20*4.9
	80, 85	22*5.4
	90, 95	25*5.4
4040	100, 105, 110	28*6.4
	115, 120, 125	32*7.4
	60, 65	18*4.4
	70, 75	20*4.9
4040	80, 85	22*5.4
	90, 95	25*5.4
	100, 105, 110	28*6.4
	115, 120, 125	32*7.4



广州西冠机电设备有限公司

锥套型号	L	A	D	安装螺栓 直径×长度 英寸 (inch)
1008	7/8	1.386	1-21/64	1/4×1/2
1108	7/8	1.511	1-29/64	1/4×1/2
1210	1	1-7/8	1-3/4	3/8×5/8
1610	1	2-1/4	2-1/8	3/8×5/8
1615	1-1/2			
2012	1-1/4	2-3/4	2-5/8	7/16×7/8
2517	1-3/4	3-3/8	3-1/4	1/2×1
3020	2	4-1/4	4	5/8×1-1/4
3030	3			

锥套型号	L	A	D	安装螺栓 直径×长度 英寸 (inch)	E°
3525	2-1/2	5	4.83	1/2×1-1/2	40°
3535	3-1/2				
4030	3	5-3/4	5.54	5/8×1-3/4	40°
4040	4				
4535	3-1/2	6-3/8	6.13	3/4×2	40°
4545	4-1/2				
5040	4	7	6.72	7/8×2-1/4	37°
5050	5				