

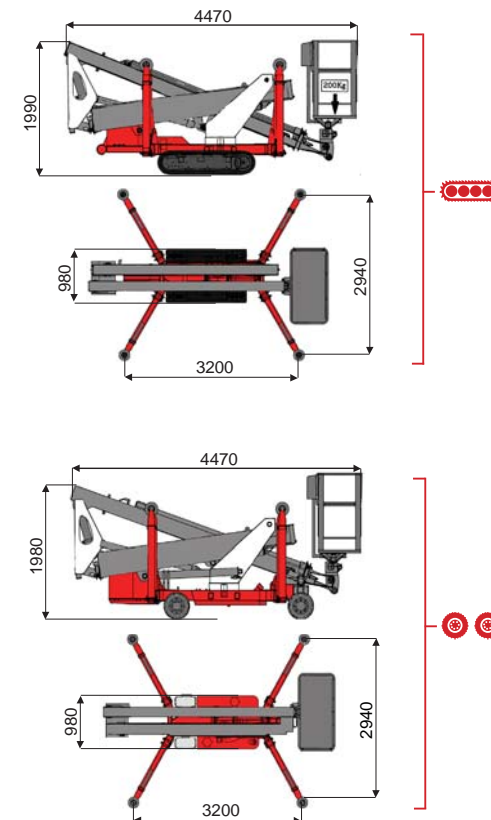

17 m ↑  
7,8 m →  
200 Kg 🧑🧑

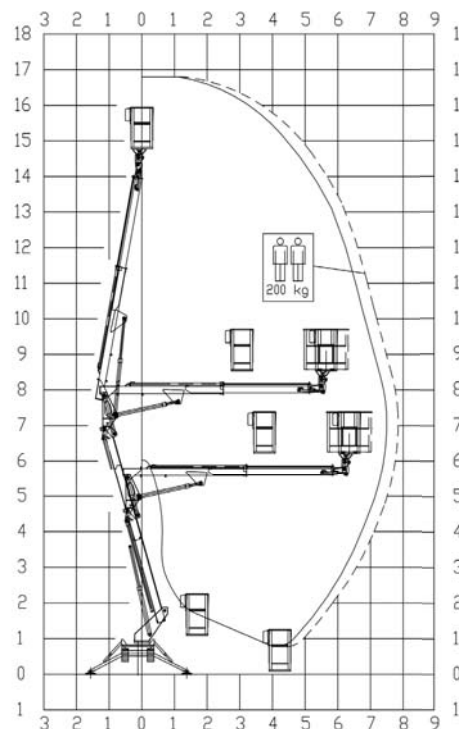

BI-ENERGY  
Diesel+AC



TZX 170/C

🔋 17 m 7,8 m 200 kg 360° 140x70 cm 90°+90° 2,94 m 15% 20% 2 km/h 2000 kg 2,6 daN/cm<sup>2</sup> 1300 daN 4,76 daN/cm<sup>2</sup> 980 mm 4470 mm 1990 mm

TZX 170/R

🔋🔋 17 m 7,8 m 200 kg 360° 140x70 cm 90°+90° 2,94 m 15% 20% 2 km/h 2000 kg 2,6 daN/cm<sup>2</sup> 1300 daN 0,36 daN/cm<sup>2</sup> 980 mm 4470 mm 1980 mm



Battery type

ECO DC+AC 🔋🔋🔋🔋



Battery charge

24V 240 A/h 5h 230V-24V 40A



Add. Weight

230 kg



Autonomy

3-4 h endless



Charging time

6h

Electropump

24V 5.5 kW



普雷斯斯特机械设备(北京)有限公司

电话: 13811539468

传真: 010-64619870

网址: <https://www.palazzani.cn>

地址: 北京通州区马驹桥兴贸一街7号U谷科创中心B座301-3

