

AR254 Hall-effect sensor is a temperature stable, stress-resistant, Low Tolerance of sensitivity micro-power switch. Superior high-temperature performance is made possible through a dynamic offset cancellation that utilizes chopper-stabilization. This method reduces the offset voltage normally caused by device over molding, temperature dependencies, and thermal stress.

AR254 is special made for low operation voltage, 1.65V, to active the chip which is includes the following on a single silicon chip: voltage regulator, Hall voltage generator, small-signal amplifier, chopper stabilization, Schmitt trigger, CMOS output driver. Advanced CMOS wafer fabrication processing is used to take advantage of low-voltage requirements, component matching, very low input-offset errors, and small component geometries. This device requires the presence of unipolar magnetic fields for operation.

The package type is in a Halogen Free version has been verified by third party Lab.

Features and Benefits

- CMOS Hall IC Technology
- Strong RF noise protection
- 1.65 to 6V for battery-powered applications
- Operation down to 1.65V, Unipolar Hall Switch Micro power consumption
- High Sensitivity for reed switch replacement applications
- Low sensitivity drift in crossing of Temp. range
- Ultra Low power consumption at 5uA (Avg)
- High ESD Protection, HBM > ±4KV(min)
- Totem-pole output
- RoHS compliant 2011/65/EU and Halogen Free

Applications

- Solid state switch
- Handheld Wireless Handset Awake Switch (Flip Cell/PHS Phone/Note Book/Flip Video Set)
- Magnet proximity sensor for reed switch replacement in low duty cycle applications
- Water Meter
- PDA
- PDVD
- NB
- Pad PC

Ordering Information

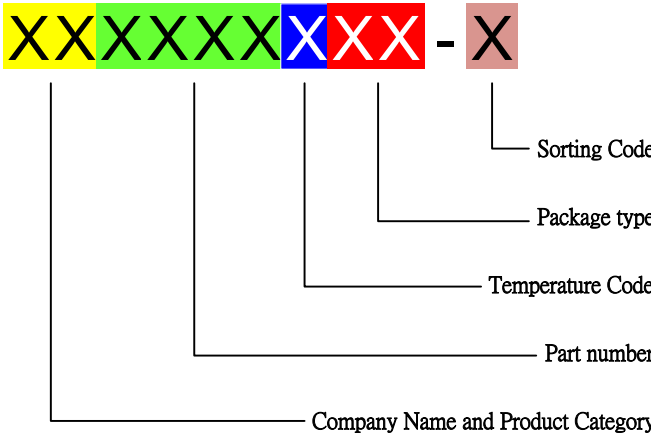
	<p>Company Name and Product Category</p> <p>Part number 181,182,183,184,185,248,249,276,477,381,381F,381R,382..... If part # is just 3 digits, the forth digit will be omitted.</p> <p>Temperature range E: 85 °C, I: 105 °C, K: 125 °C, L: 150 °C</p> <p>Package type UA:TO-92S,VK:TO-92S(4pin),VF:TO-92S(5pin),SO:SOT-23, SQ:QFN-3,ST:TSOT-23,SN:SOT-553,SF:SOT-89(5pin); SS:TSOT-26,SD:DFN-6</p> <p>Sorting α, β, Blank.....</p>
---	--

Part No.	Temperature Suffix	Package Type
AR254EUA	E (-40°C to + 85°C)	UA(TO-92S)
AR254EST	E (-40°C to + 85°C)	ST (TSOT-23)
AR254ESN	E (-40°C to + 85°C)	SN (SOT-553)
AR254ESQ	E (-40°C to + 85°C)	SQ (QFN2020-3)
AR254ESS	E (-40°C to + 85°C)	SS (QFN1x1x0.4)

Custom sensitivity selection is available by AR sorting technology

Functional Diagram

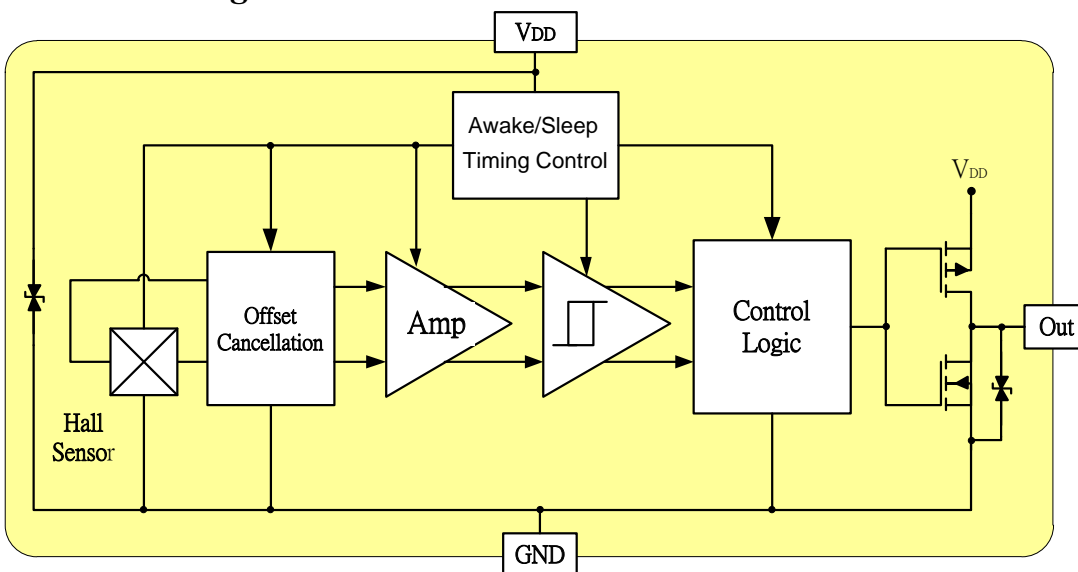

Note: Static sensitive device; please observe ESD precautions. Reverse V_{DD} protection is not included. For reverse voltage protection, a 100Ω resistor in series with V_{DD} is recommended.
AR254, HBM > ±4KV which is verified by third party lab.

Absolute Maximum Ratings At($T_a=25\text{ }^\circ\text{C}$)

Characteristics	Values	Unit
Supply voltage, (V_{DD})	7	V
Output Voltage, (V_{out})	7	V
Reverse Voltage, (V_{DD}) (V_{out})	-0.3	V
Magnetic flux density	Unlimited	Gauss
Output current, (I_{out})	1	mA
Operating temperature range, (T_a)	-40 to +85	$^\circ\text{C}$
Storage temperature range, (T_s)	-65 to +150	$^\circ\text{C}$
Maximum Junction Temp, (T_j)	150	$^\circ\text{C}$
Thermal Resistance	(θ_{JA}) ST/SN/UA/SQ/SS	310/540/206/540/540
	(θ_{JC}) ST/SN/UA/SQ/SS	223/390/148/390/390
Package Power Dissipation, (P_D) ST/SN/UA/SQ/SS	400/230 /606/230/230	mW

Note: Exceeding the absolute maximum ratings may cause permanent damage. Exposure to absolute maximum-rated conditions for extended periods may affect device reliability.

Electrical Specifications

DC Operating Parameters : $T_a=25\text{ }^\circ\text{C}$, $V_{DD}=1.8\text{V}$

Parameters	Test Conditions	Min	Typ	Max	Units
Supply Voltage, (V_{DD})	Operating	1.65		6	Volts
Supply Current, (I_{DD})	Awake State		1.4	3	mA
	Sleep State		3.6	7	μA
	Average		5	10	μA
Output Leakage	Output off			1	μA
Output High Voltage, (V_{OH})	$I_{OUT}=0.5\text{mA}$ (Source)	$V_{DD}-0.2$			V
Output Low Voltage, (V_{OL})	$I_{OUT}=0.5\text{mA}$ (Sink)			0.2	V
Awake mode time, (T_{aw})	Operating		40	80	μs
Sleep mode time, (T_{sl})	Operating		40	80	mS
Duty Cycle, (D,C)			0.1		%
Electro-Static Discharge	HBM	4			KV

Typical application circuit

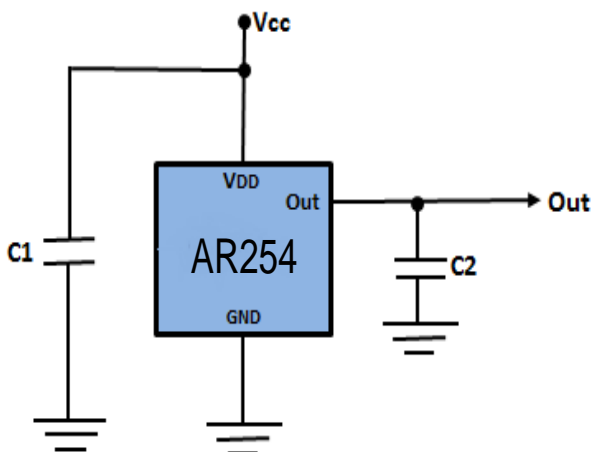

C1 : 10nF
 C2 : 100pF

AR254E ST/UA/SQ/SS Magnetic Specifications

DC Operating Parameters : $T_a=25^{\circ}\text{C}$, $V_{DD}=2.0\text{V}$

Parameter	Symbol	Test Conditions	Min.	Typ.	Max.	Units
Operating Point	B_{OP}	N pole to branded side, $B > B_{OP}$, Vout On	-50	-30		Gauss
Release Point	B_{RP}	N pole to branded side, $B < B_{RP}$, Vout Off		-20	-10	Gauss
Hysteresis	B_{HY}	$ B_{OPx} - B_{RPx} $		10		Gauss

AR254E SN Magnetic Specifications

DC Operating Parameters : $T_a=25^{\circ}\text{C}$, $V_{DD}=2.0\text{V}$

Parameter	Symbol	Test Conditions	Min.	Typ.	Max.	Units
Operating Point	B_{OP}	S pole to branded side, $B > B_{OP}$, Vout On		30	50	Gauss
Release Point	B_{RP}	S pole to branded side, $B < B_{RP}$, Vout Off	10	20		Gauss
Hysteresis	B_{HY}	$ B_{OPx} - B_{RPx} $		10		Gauss

AR254E ST/SQ/SS/SN/UA Output Behavior versus Magnetic Polar

DC Operating Parameters : $T_a = -40$ to 85°C , $V_{DD} = 1.65\text{V}$ to 6V

Parameter	Test condition	OUT (ST/SS/SQ/UA)	Parameter	Test condition	OUT(SN)
Null or weak magnetic field	$B=0$ or $B < B_{RP}$	High	Null or weak magnetic field	$B=0$ or $B < B_{RP}$	High
North pole	$B < B_{op-N}$	Low	South pole	$B > B_{op-S}$	Low

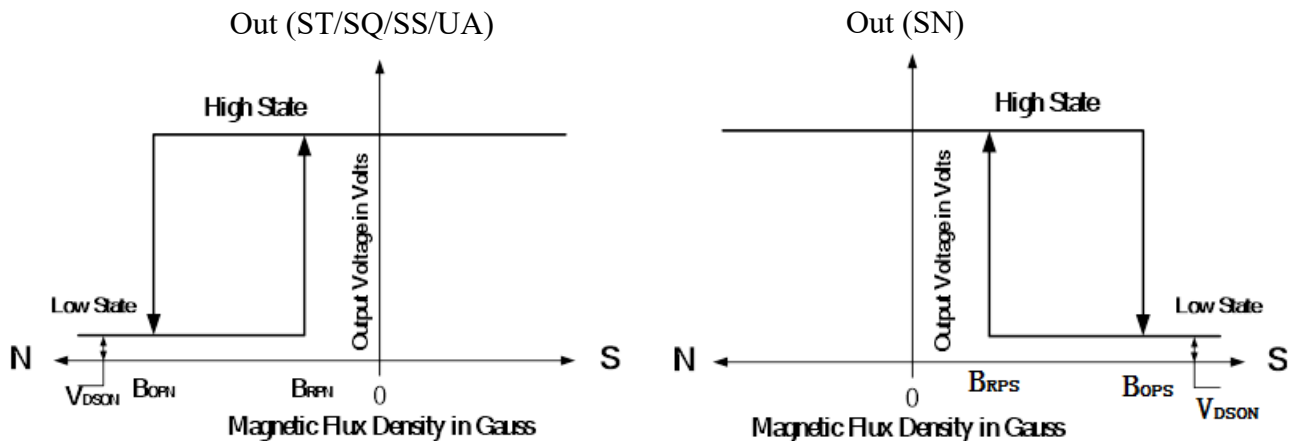

Performance Graph

Typical Supply Voltage (V_{DD}) Versus Flux Density

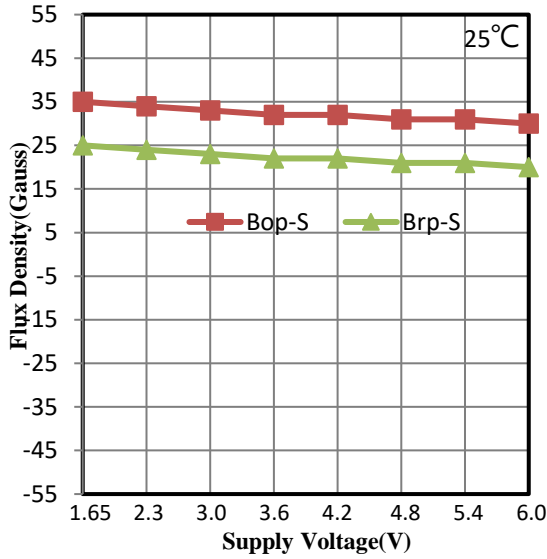

Typical Temperature (T_A) Versus Flux Density

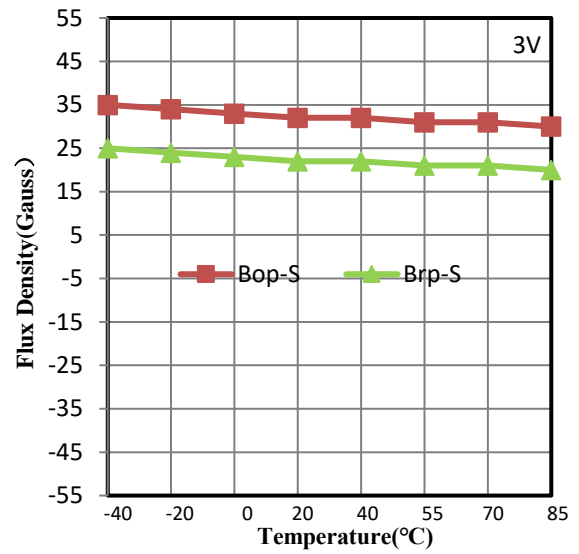

Typical Supply Voltage (V_{DD}) Versus Flux Density

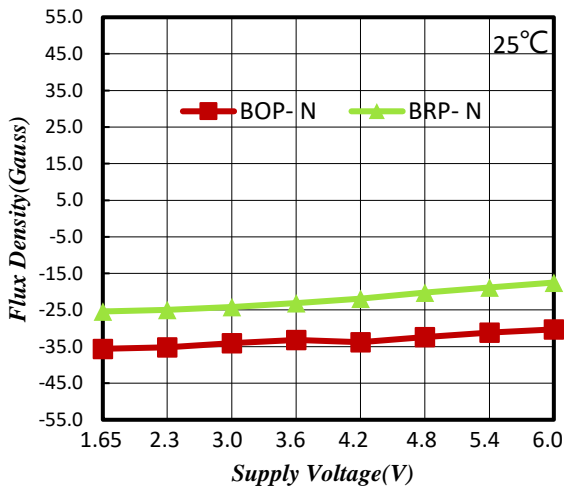

Typical Temperature (T_A) Versus Flux Density

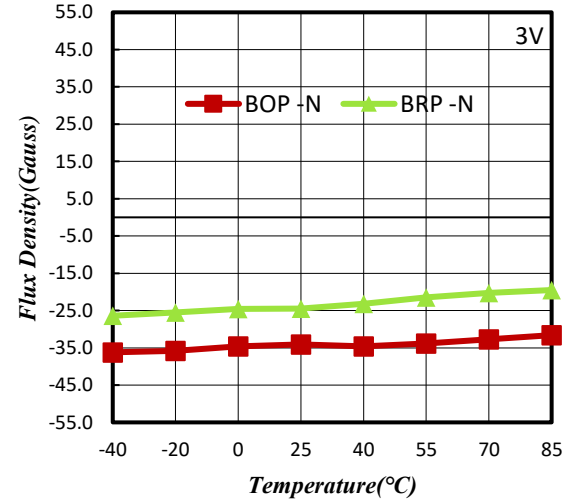

Typical Temperature (T_A) Versus Supply Current (I_{DD})

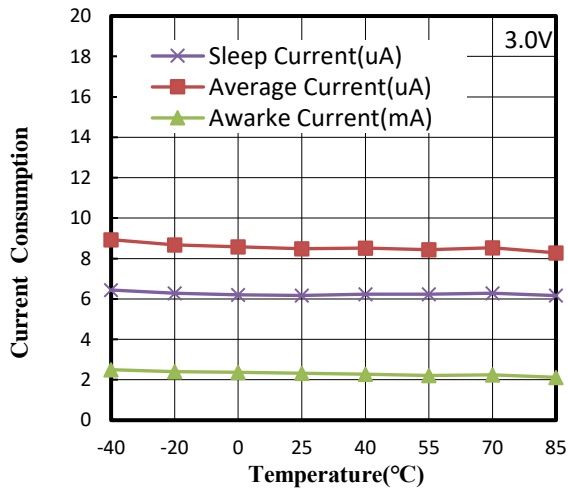

Typical Supply Voltage (V_{DD}) Versus Supply current current (I_{DD})

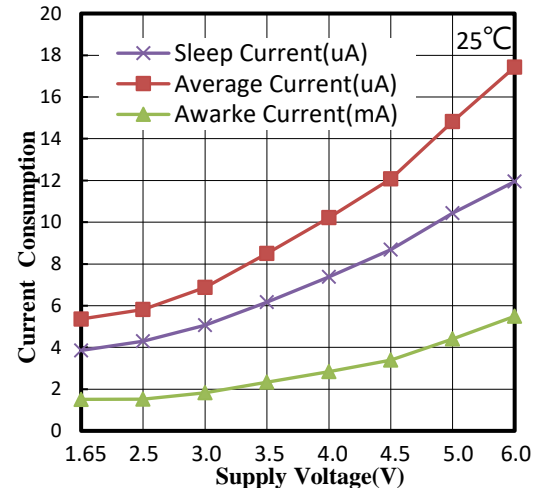

Typical Supply Voltage (V_{DD}) Versus Output Voltage (V_{DSON})

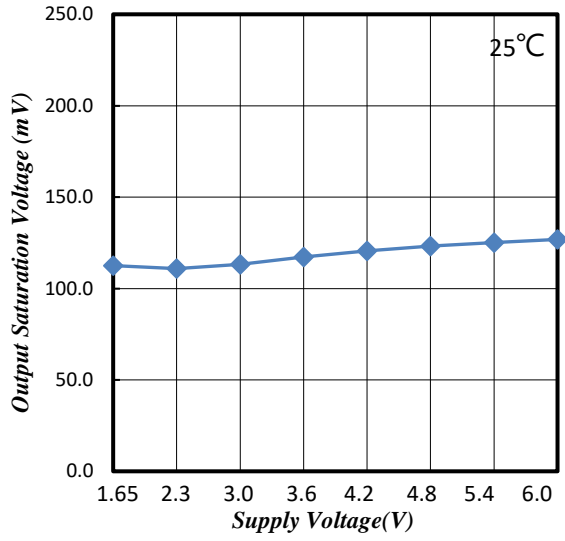

Typical Temperature (T_A) Versus Output Voltage (V_{DSON})

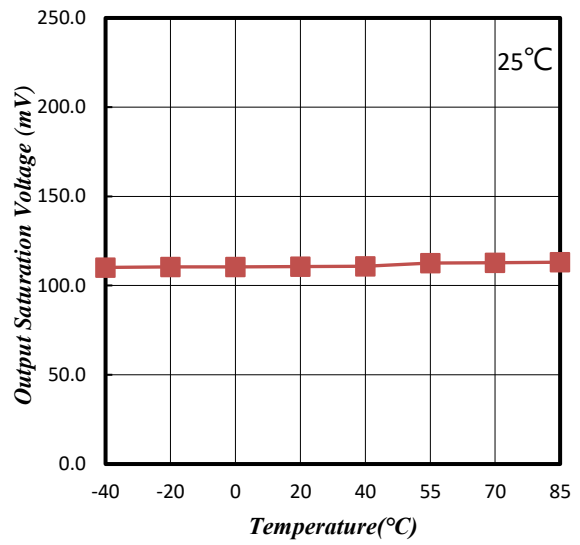

Typical Supply Voltage (V_{DD}) Versus Leakage Current (I_{OFF})

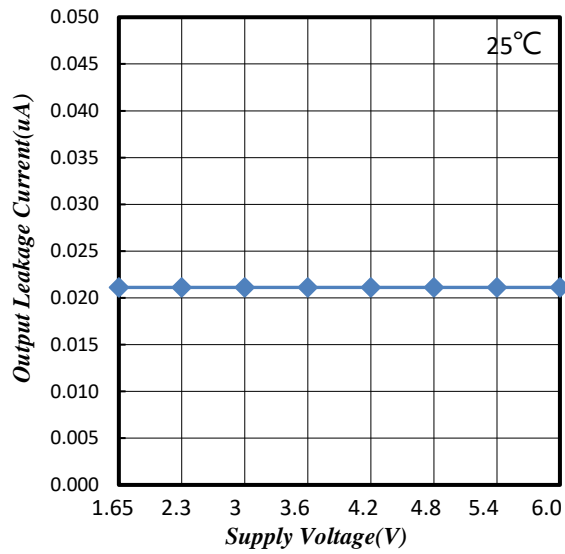

Power Dissipation versus Temperature (T_A)

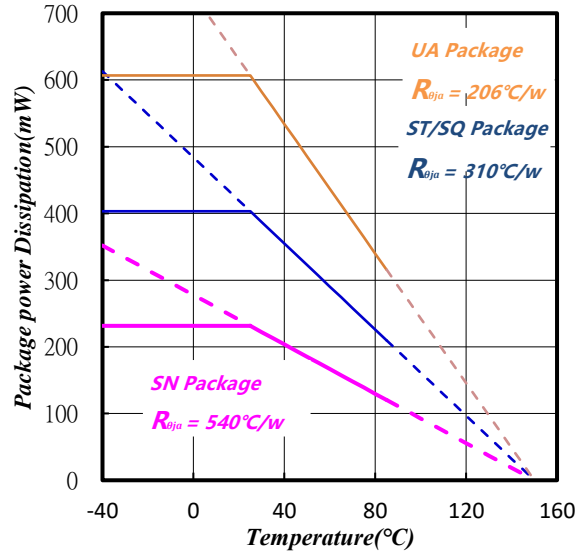

Package Power Dissipation

The power dissipation of the Package is a function of the pad size. This can vary from the minimum pad size for soldering to a pad size given for maximum power dissipation. Power dissipation for a surface mount device is determined by $T_{J(max)}$, the maximum rated junction temperature of the die, $R_{\theta JA}$, the thermal resistance from the device junction to ambient, and the operating temperature, T_a . Using the values provided on the data sheet for the package, PD can be calculated as follows:

$$P_D = \frac{T_{J(max)} - T_a}{R_{\theta ja}}$$

The values for the equation are found in the maximum ratings table on the data sheet. Substituting these values into the equation for an ambient temperature T_a of 25°C, one can calculate the power dissipation of the device which in this case is 400 milliwatts.

$$P_D(ST) = \frac{150^\circ\text{C} - 25^\circ\text{C}}{310^\circ\text{C}/\text{W}} = 400\text{mW}$$

The 310°C/W for the SN package assumes the use of the recommended footprint on a glass epoxy printed circuit board to achieve a power dissipation of 400 milliwatts. There are other alternatives to achieving higher power dissipation from the Package. Another alternative would be to use a ceramic substrate or an aluminum core board such as Thermal Clad. Using a board material such as Thermal Clad, an aluminum core board, the power dissipation can be doubled using the same footprint.

Sensor Location, package dimension and marking

AR254 Package

ST Package(TSOT-23)
(Top View)

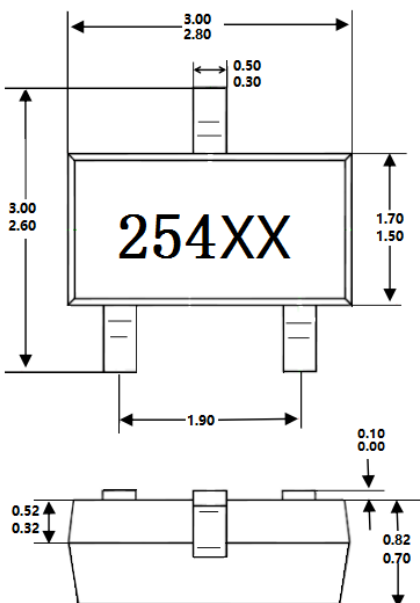

Hall Plate Chip Location
(Bottom view)

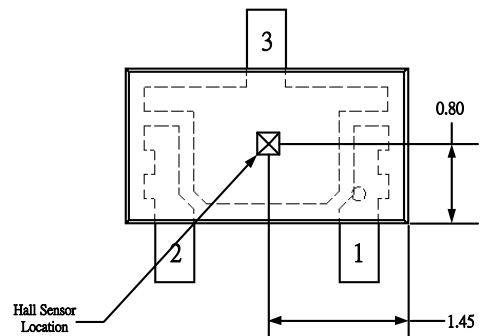

NOTES:

- PINOUT (See Top View at left:)
 Pin 1 VDD
 Pin 2 Output
 Pin 3 GND
- Controlling dimension: mm;

SS Package (DFN 1.0*1.0)

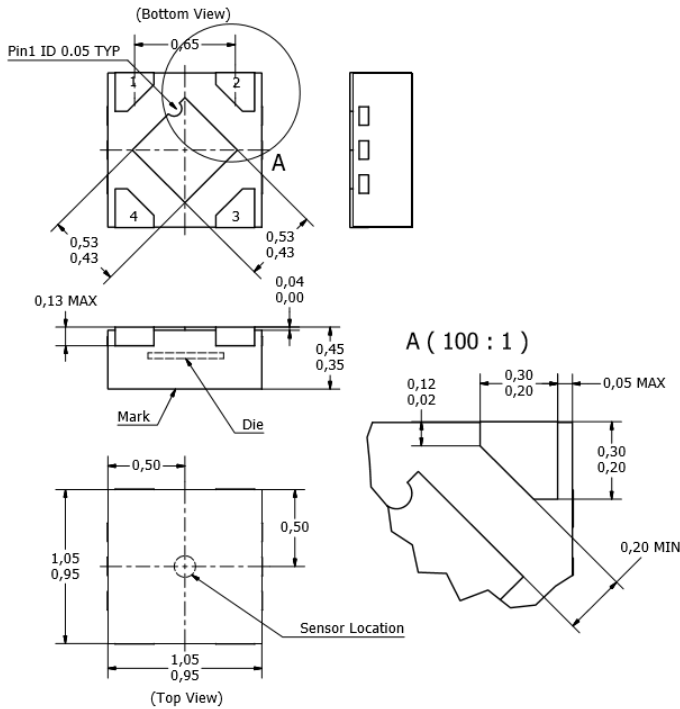

NOTES:

1. Controlling dimension: mm
2. Leads must be free of flash and plating voids
3. Lead thickness after solder plating will be 0.254mm maximum
4. PINOUT:

Pin No.	Pin Name	Function
1	V _{DD}	Power Supply
2	GND	Ground
3	SPD	
4	V _{OUT}	Output

5. (For reference only) Land Pattern

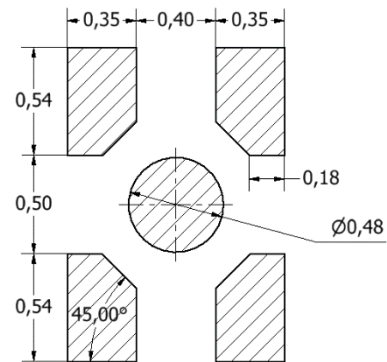

SN Package (SOT-553) (Top View)

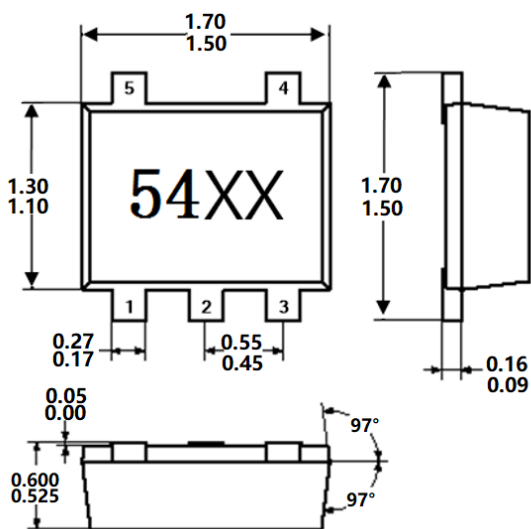

Hall Plate Chip Location (Top View)

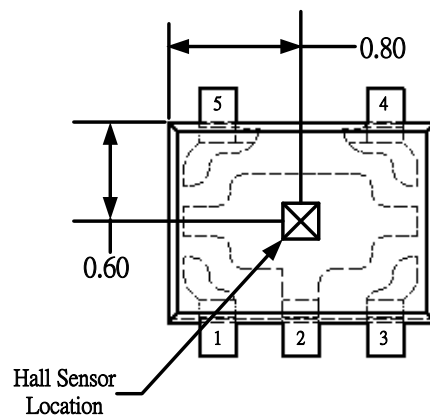

NOTES:

1. PINOUT (See Top View at left:)
 Pin 1 NC
 Pin 2 GND
 Pin 3 NC
 Pin 4 V_{DD}
 Pin 5 Out
2. Controlling dimension: mm;

SQ Package (QFN2020-3)

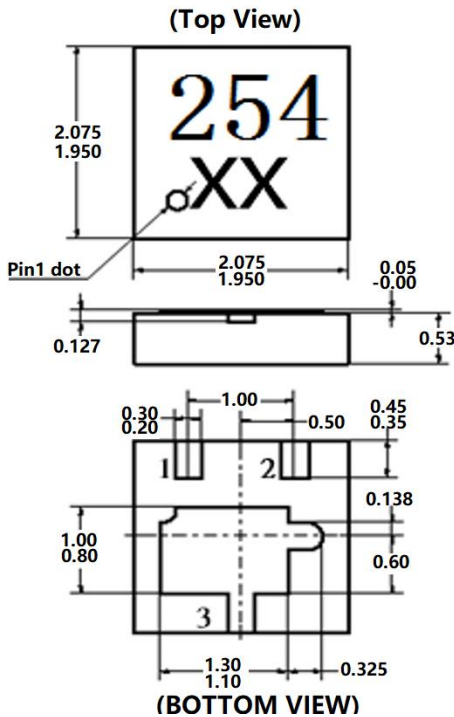

Hall Plate Chip Location

(Top view)

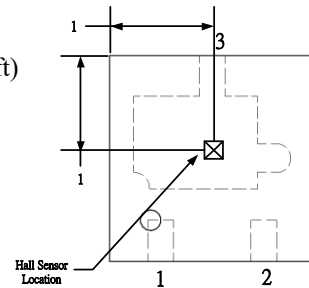

NOTES:

3. PINOUT (See Top View at left)
 Pin 1 VDD
 Pin 2 Output
 Pin 3 GND
4. Controlling dimension: mm;
5. Chip rubbing will be 10mil maximum;
6. Chip must be in PKG. center.

UA Package (TO-92S)

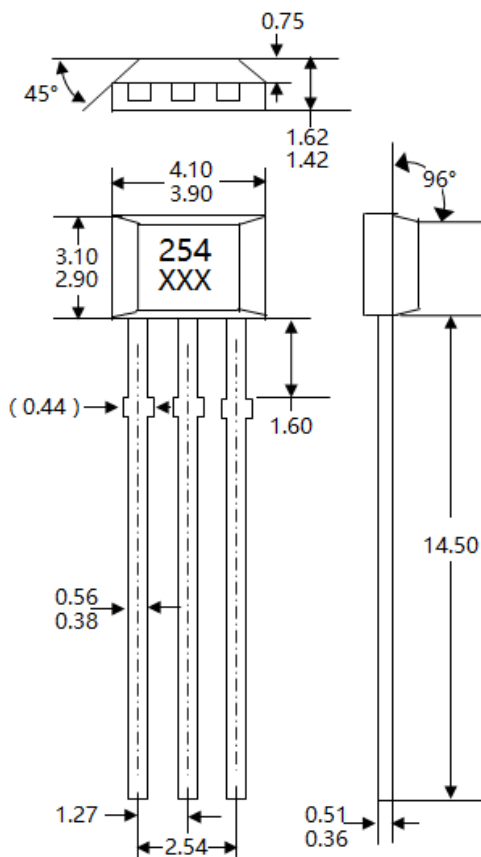

Hall Chip location

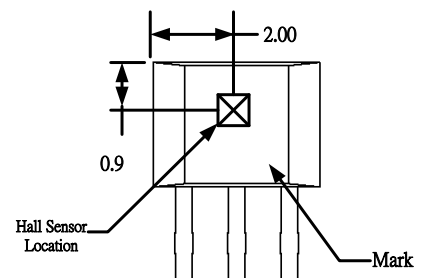

Output Pin Assignment

(Top view)

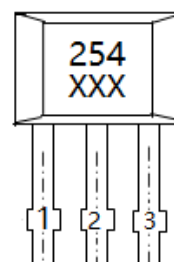

NOTES:

- 1).Controlling dimension: mm
- 2).Leads must be free of flash and plating voids
- 3).Do not bend leads within 1 mm of lead to package interface.
- 4).PINOUT:
 Pin 1 VDD
 Pin 2 GND
 Pin 3 Output

SOT-553 Tape On Reel Dimension

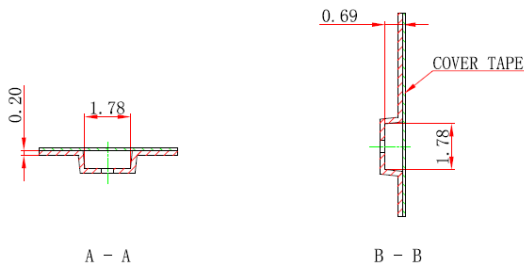
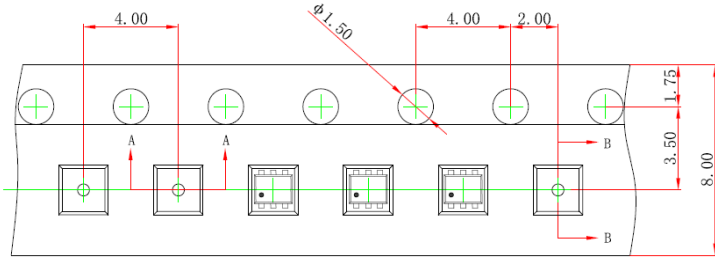

NOTES:

1. Material: Conductive polystyrene;
2. DIM in mm;
3. 10 sprocket hole pitch cumulative tolerance ± 0.2 ;
4. Camber not to exceed 1mm in 100mm;
5. Pocket position relative to sprocket hole measured as true position of pocket, not pocket hole;
6. (S.R. OHM/SQ) Means surface electric resistivity of the carrier tape.

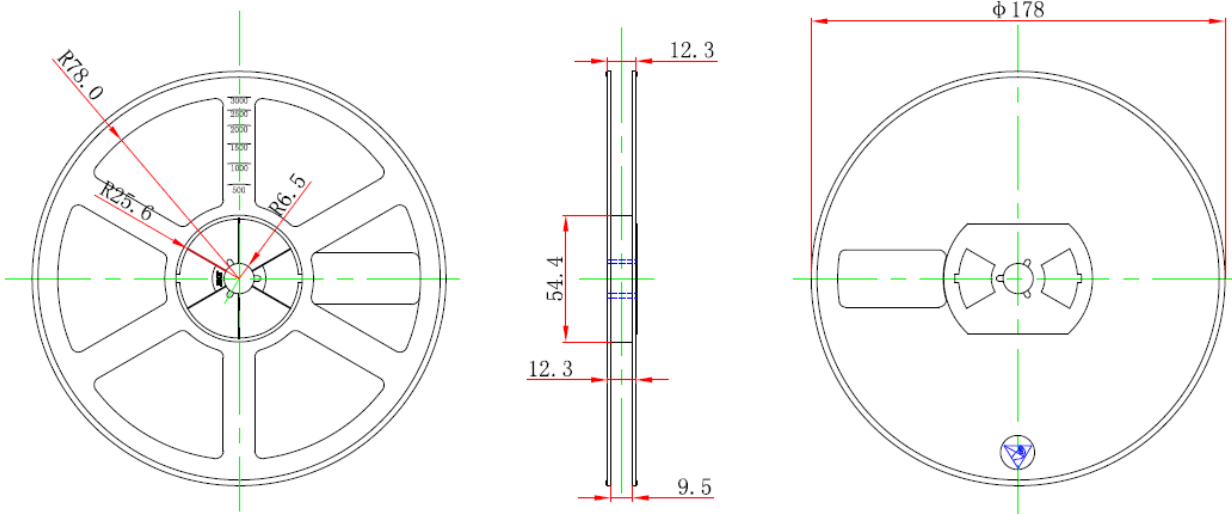

SS (DFN 1.0x1.0-4) Tape On Reel Dimension

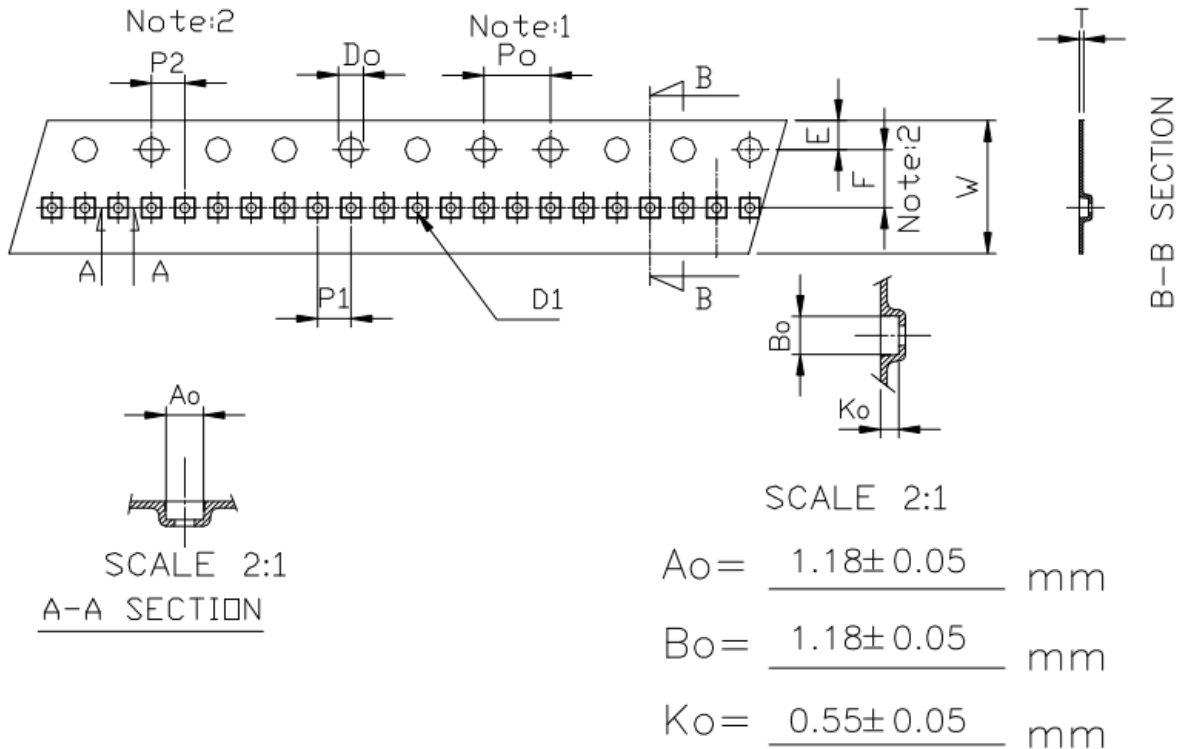

Unit: mm

Symbol	Spec.
Po	4.0±0.10
P1	2.0±0.05
P2	2.0±0.05
Do	1.50 ^{+0.1} _{-0.}
D1	0.5 ^{+0.05} _{-0.05}
E	1.75±0.10
F	3.45±0.05
10Po	40.0±0.10
W	8.0±0.20
T	0.20±0.05

NOTES:

- 10 sprocket hole pitch cumulative tolerance is ±0.1mm;
- Pocket position relative to sprocket hole measured as true position of pocket, not pocket hole;
- Ao & Bo measured on a place 0.3mm above the bottom of the pocket to top surface of the carrier.
- Ko measured from a plane on the inside bottom of the pocket to the top surface of the carrier.
- Carrier camber shall be not than 1mm per 100mm through a length of 250m.



Width	1	2	3	4	5	6	7	8	9
7"	178±1	60±0.5	13.2±0.5	2.2±0.5	3 ^{+0.5} ₋₀	4 ^{+0.5} ₋₀	5.0 ^{+0.5} ₋₀	9±0.5	12±0.5

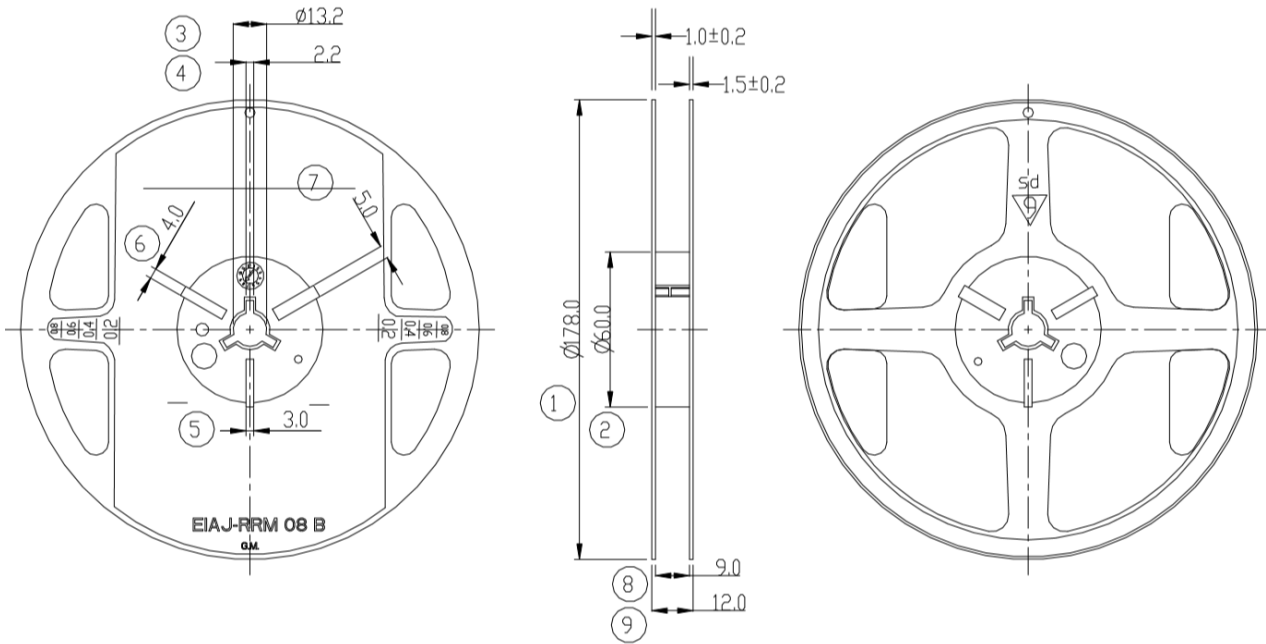

IR reflow curve

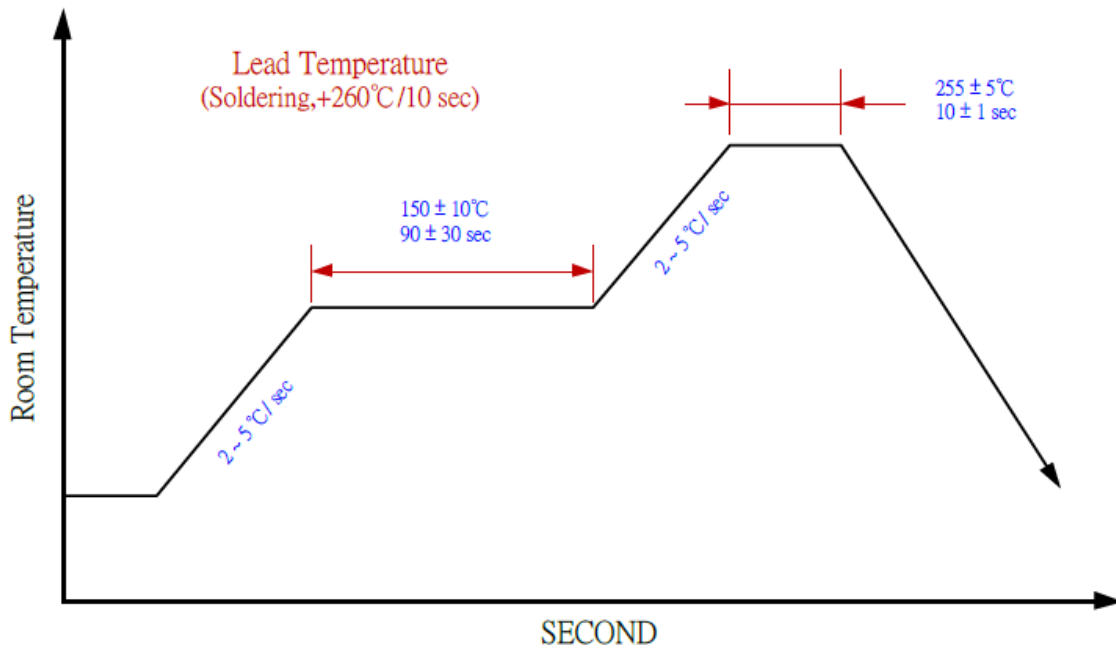

ST/SN/SS/SQ Soldering Condition

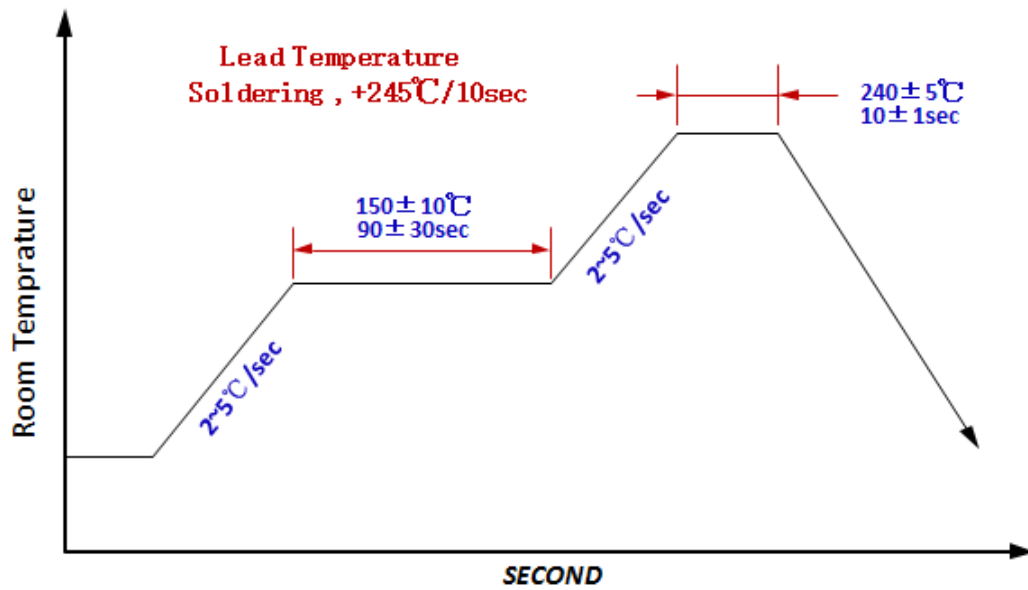

UA Soldering Condition

Packing specification:

Package	Bag	Box	Carton
TSOT-23(ST)	3,000pcs/reel	10 reel/box	2 box/carton
SOT-553(SN)	3,000pcs/reel	10 reel/box	2 box/carton
TO-92S-3L(UA)	1,000pcs/bag	10bag/box	10 box/carton
QFN2020-3(SQ)	3,000pcs/reel	10 reel/box	2 box/carton
SS(DFN1.0x1.0)	8,000pcs/reel	5reel/box	12 box/carton

TSOT-23-3L	Weight	SOT-553(SN)	Weight	TO-92S-3L(UA)	Weight
3000pcs/reel	0.18kg	3000pcs/reel	0.13kg	1000pcs/bag	0.11kg
10 reels/box	1.99kg	10 reels/box	1.40kg	10bags/box	1.24kg
2 boxes/carton	4.9kg	2 boxes/carton	3.70kg	10 boxes/carton	12.57kg

QFN2020-3(SQ)	Weight	SS(DFN1.0x1.0)	Weight
3000pcs/reel	0.13kg	8,000pcs/reel	0.11kg
10 reels/box	1.40kg	5 reels/box	0.66kg
2 boxes/carton	3.70kg	12boxes/carton	8.72kg